

Flygt 3301.090/180

Table of Contents

1 Introduction.....	2
1.1 Specially approved products.....	2
2 Product Description.....	3
2.1 The data plate.....	3
2.2 Approvals.....	4
2.3 Product denomination.....	5
3 Exploded View.....	7
3.1 Drive Unit.....	7
3.1.1 Standard and explosion-proof.....	7
3.2 Hydraulic Unit.....	8
3.2.1 N_ MT.....	8
3.2.2 N_ HT.....	9
3.2.3 N_ LT.....	10
3.2.4 N_ LT.....	11
3.3 Installation Components.....	12
3.3.1 NP.....	12
3.3.2 NS.....	13
3.3.3 NT.....	14
3.3.4 NZ.....	15
4 List of Parts.....	17
4.1 3301.090/180.....	17

1 Introduction

Purpose of this manual

The purpose of this manual is to provide necessary information on spare parts and accessories order.

Disclaimer

Always use genuine Flygt parts. The use of other spare parts or accessories can invalidate any claims for warranty or compensation. Xylem does not take any responsibility for damages that are caused by the use of non-original parts. For more information, contact your local sales and service representative.

Data for ordering spare parts

The following information is needed for spare part orders:

- Serial number of the product
- Part number
- Quantity of bulk material, see * in tables

1.1 Specially approved products

Qualification of personnel

Only Xylem or Xylem-authorized service personnel may undertake repair work on specially approved products.

Dimensional accuracy inspection

Spare parts marked with (Ex) after the part number are subject to dimensional accuracy inspection when used in specially approved products.

2 Product Description

2.1 The data plate

The data plate is a metal label that is located on the main body of the products. The data plate lists key product specifications. Specially approved products also have an approval plate.

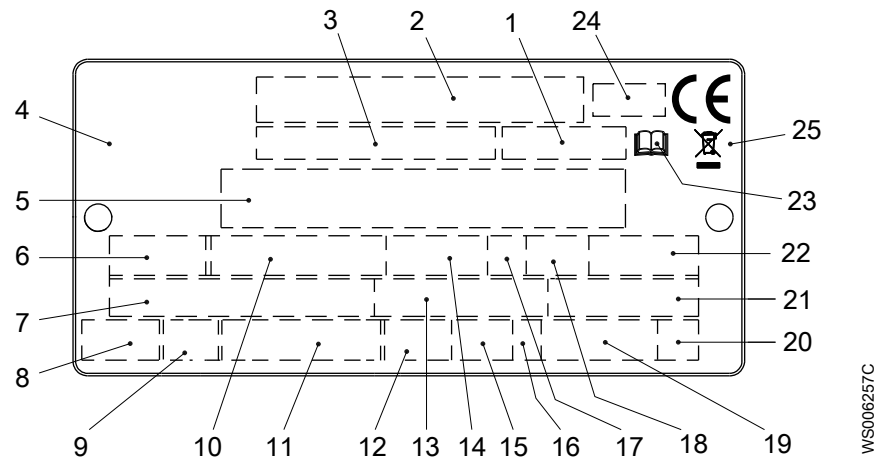



1. Curve code or Propeller code
2. Serial number
3. Product number
4. Country of origin
5. Additional information
6. Phase; type of current; frequency
7. Rated voltage
8. Thermal protection
9. Thermal class
10. Rated shaft power
11. International standard
12. Degree of protection
13. Rated current
14. Rated speed
15. Maximum submergence
16. Direction of rotation: L=left, R=right
17. Duty class
18. Duty factor
19. Product weight
20. Locked rotor code letter
21. Power factor
22. Maximum ambient temperature
23. Read installation manual
24. Notified body, only for EN-approved Ex products
25. WEEE-Directive symbol

Figure 1: The data plate

2.2 Approvals

Product approvals for hazardous locations

Pump	Approval
<ul style="list-style-type: none"> • 3301.090 	European Norm (EN) <ul style="list-style-type: none"> • ATEX Directive • EN 60079-0:2012/A11:2013, EN 60079-1:2014, EN ISO 80079-36:2016, EN ISO 80079-37:2016 •  II 2 G Ex db h IIB T3 Gb •  I M2 Ex db h I Mb
	IEC <ul style="list-style-type: none"> • IECEx scheme • IEC 60079-0:2011, IEC 60079-1:2014; IEC 80079-36:2016; IEC 80079-37:2016 • Ex db h IIB T3 Gb • Ex db h I Mb
	FM (FM Approvals) <ul style="list-style-type: none"> • Explosion proof for use in Class I, Div. 1, Group C and D • Dust ignition proof for use in Class II, Div. 1, Group E, F and G • Suitable for use in Class III, Div. 1, Hazardous Locations
	CSA Ex <ul style="list-style-type: none"> • Explosion proof for use in Class I, Div. 1, Group C and D

EN approval plate

This illustration describes the EN approval plate and the information that is contained in its fields.

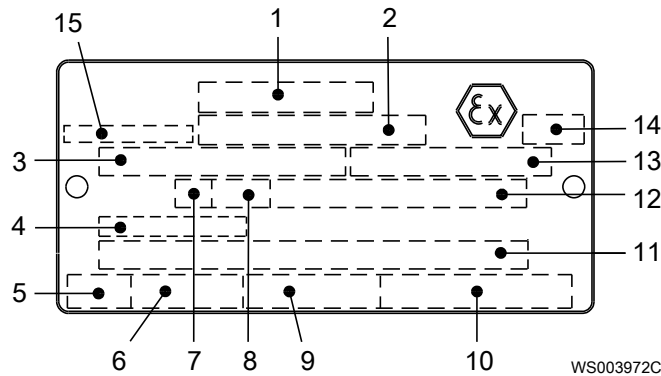

1. Approval
2. Approval authority and Approval number
3. Approved drive unit
4. Cable entry temperature
5. Stall time
6. Starting current or Rated current
7. Duty class
8. Duty factor
9. Input power
10. Rated speed
11. Additional information
12. Maximum ambient temperature
13. Serial number
14. ATEX marking
15. Country of origin

IEC approval plate

This illustration describes the IEC approval plate and the information that is contained in its fields.

International Norm; not for EU member countries.

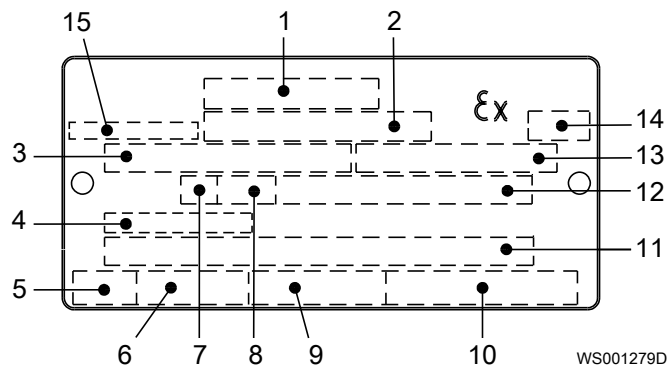

1. Approval
2. Approval authority and Approval number
3. Approved drive unit
4. Cable entry temperature
5. Stall time
6. Starting current or Rated current
7. Duty class
8. Duty factor
9. Input power
10. Rated speed
11. Additional information
12. Maximum ambient temperature
13. Serial number
14. ATEX marking
15. Country of origin

FM approval plate

This illustration describes the FM approval plate and the information that is contained in its fields.

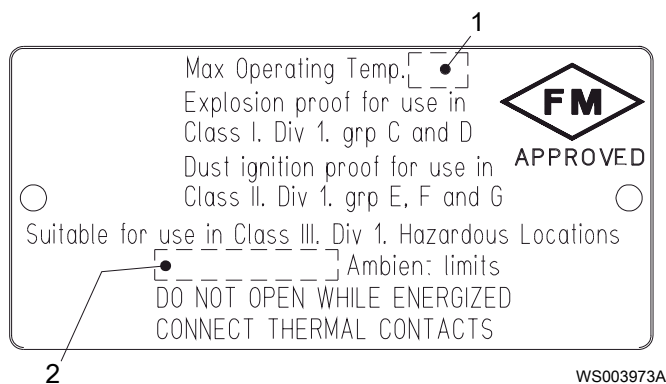

1. Temperature class
2. Maximum ambient temperature

CSA approval plate

This illustration describes the CSA approval plate and the information that is contained in its fields.

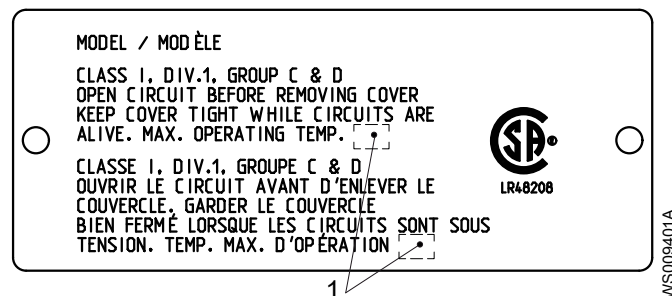

1. Temperature class

2.3 Product denomination

Reading instruction

In this section, code characters are illustrated accordingly:

X = letter

Y = digit

The different types of codes are marked up with a, b and c. Code parameters are marked up with numbers.

Codes and parameters

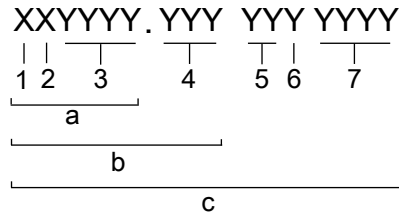

WS006265B

Type of Callout	Number	Indication
Type of code	a	Sales denomination
	b	Product code
	c	Serial number
Parameter	1	Hydraulic end
	2	Type of installation
	3	Sales code
	4	Version
	5	Production year
	6	Production cycle
	7	Running number

3 Exploded View

3.1 Drive Unit

3.1.1 Standard and explosion-proof

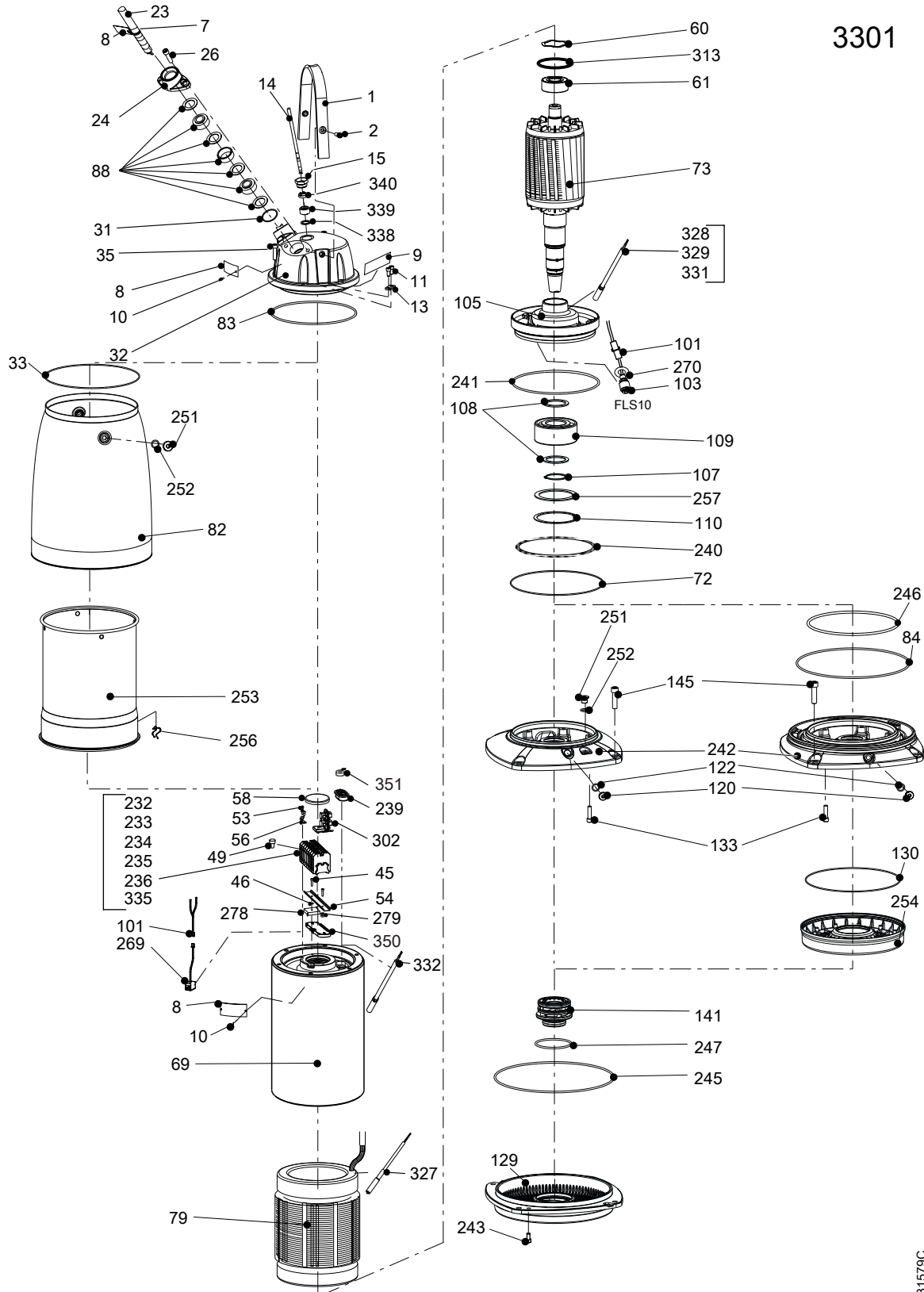

31579C

3.2 Hydraulic Unit

3.2.1 N_ MT

Curve: 630, 632, 634, 636, 638, 639

N_ 3301 MT

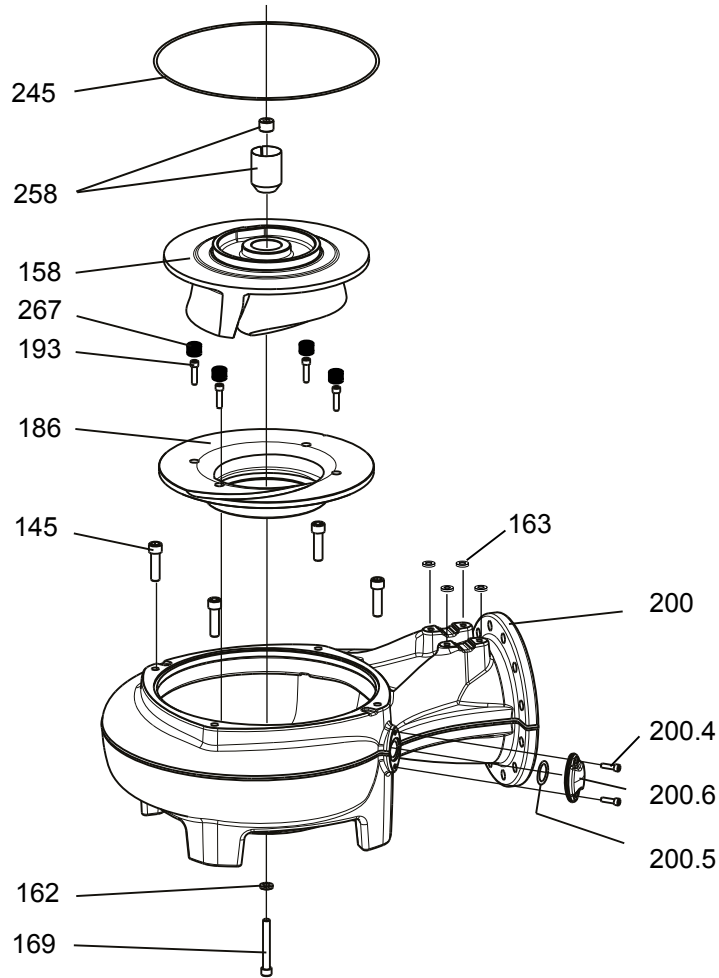

31346

3.2.2 N_HT

Curve: 450, 452, 454, 456, 458, 460, 462, 464, 466, 468

N_3301 HT

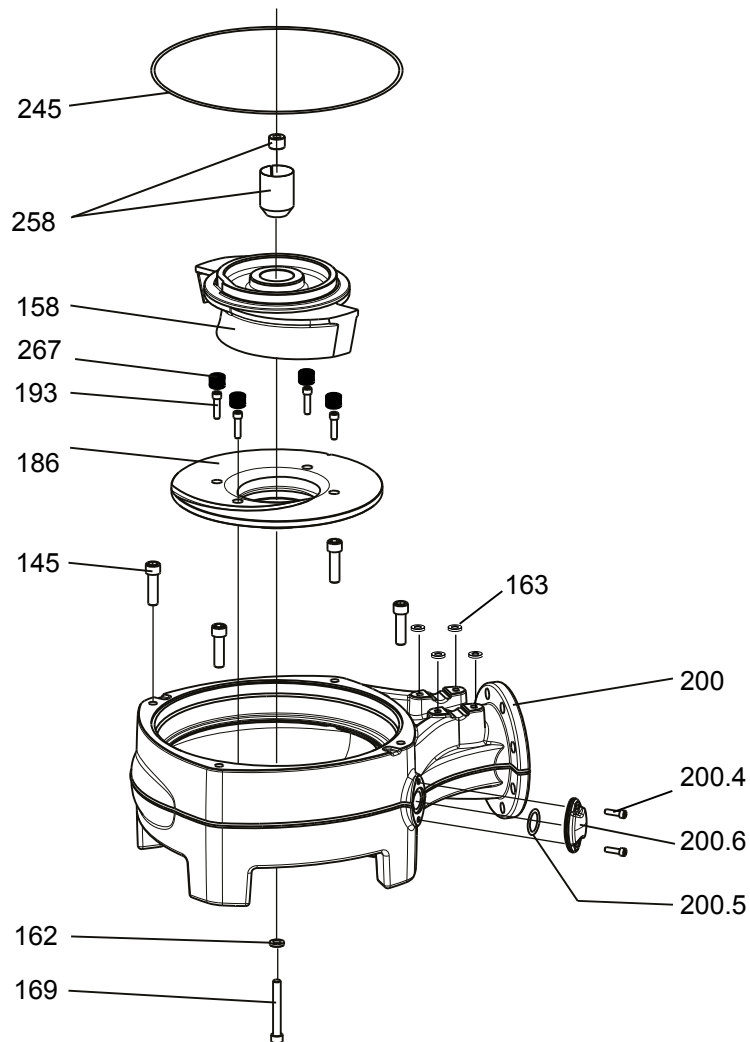

31344

3.2.3 N_LT

6-pole, curve: 620, 622, 624, 626, 628

N_3301 LT 6-pole

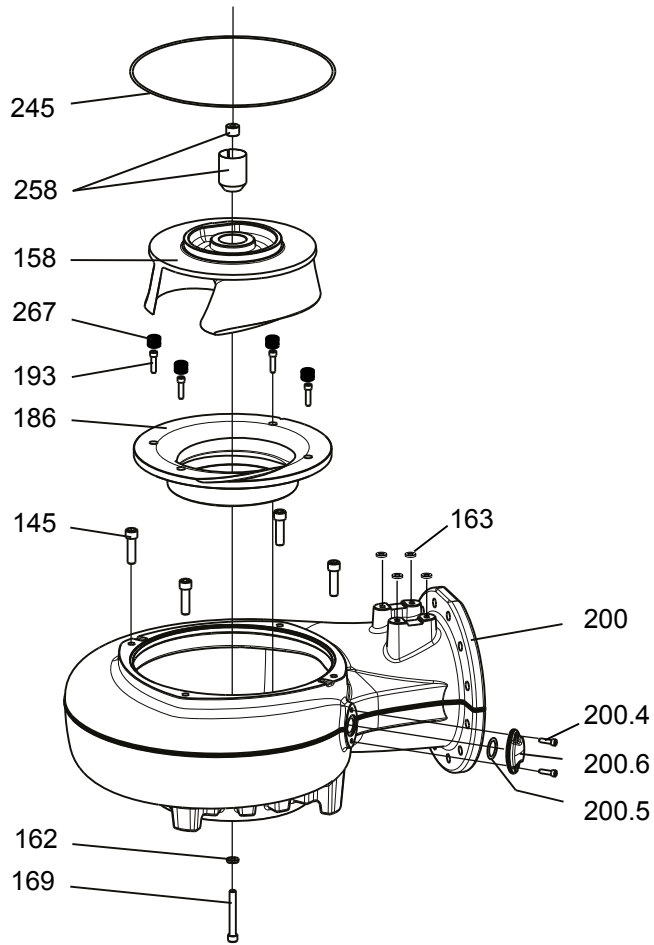

31348

3.2.4 N_LT

8-pole, curve: 810, 812, 814, 816, 818

N_3301 LT 8-pole

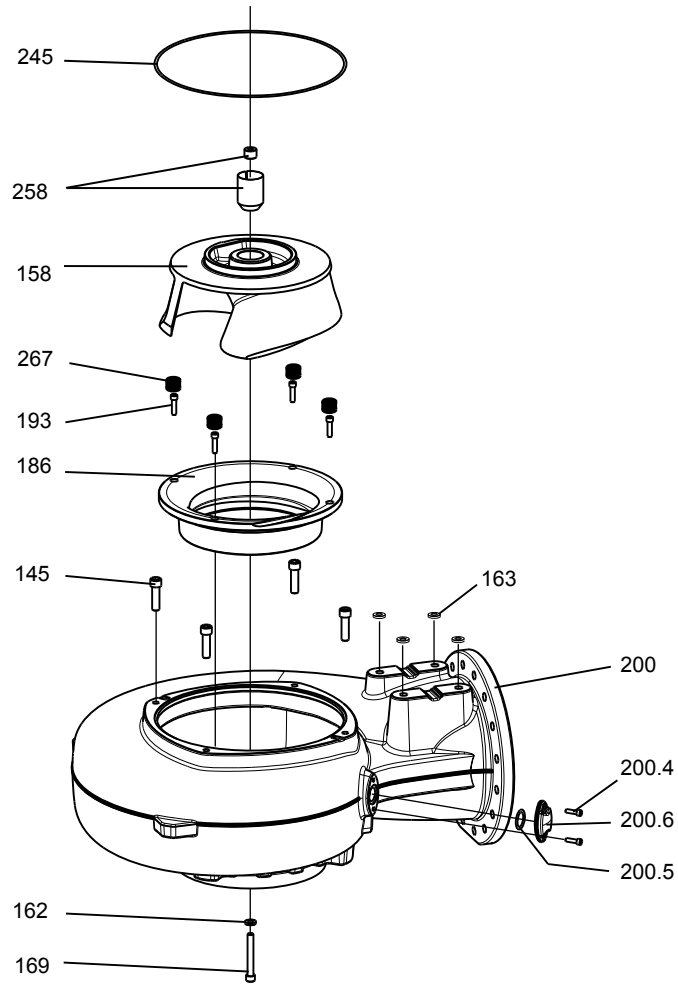

31350

3.3 Installation Components

3.3.1 NP

NP 3301

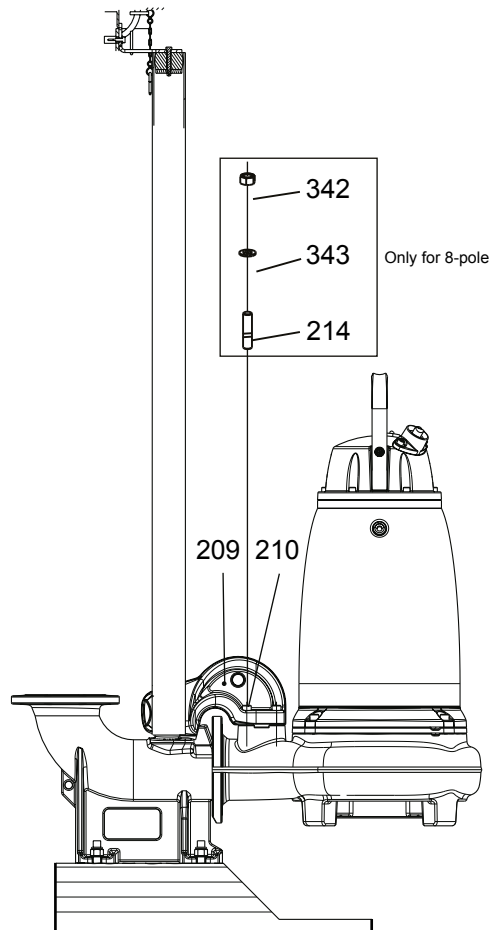

31142C

3.3.2 NS

NS 3301

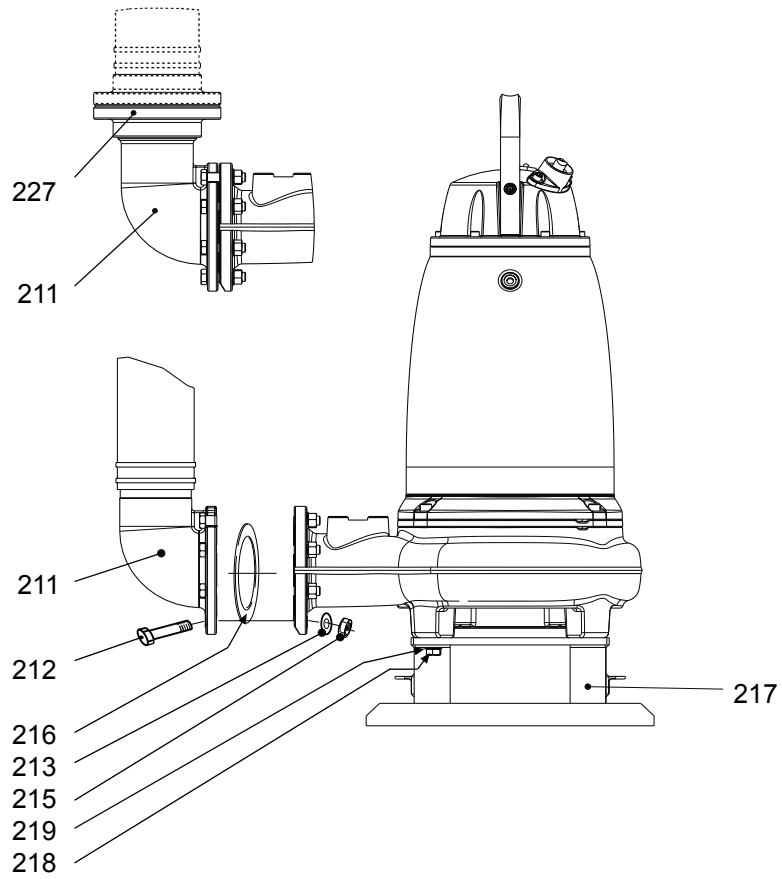

31143

3.3.3 NT

NT 3301

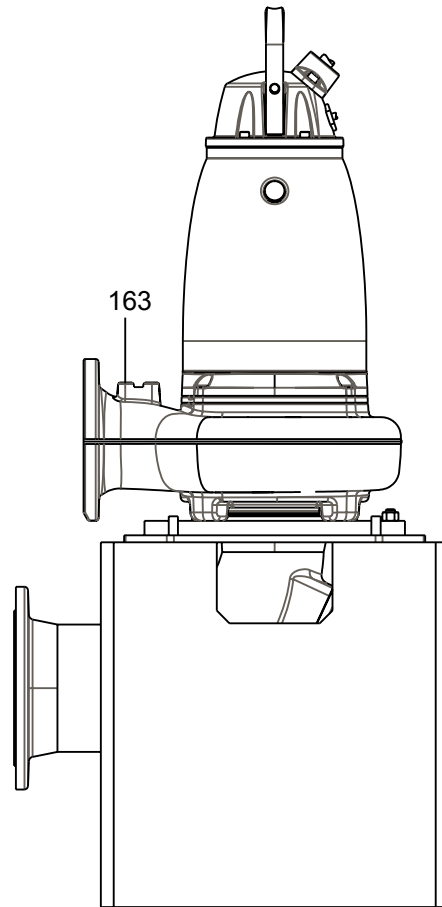

31491

3.3.4 NZ

Standard design

NZ 3301

Alt. 1

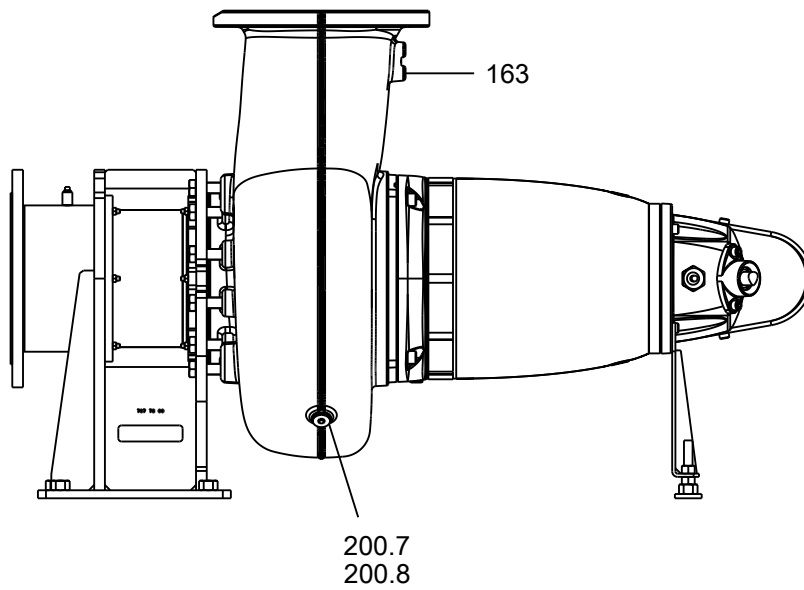

31496

Alternative design, with service cart

NZ 3301

Alt. 2

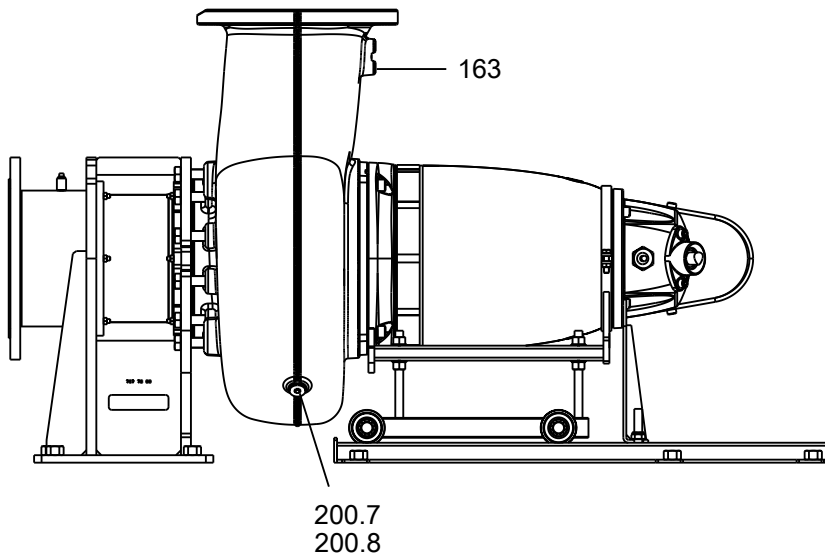

31497

For more information, refer to Mechanical Installation Equipment on TPI.

4 List of Parts

4.1 3301.090/180

Pos. No	Part. No	Type	Denomination	Qty/Version	
				090	180
1	608 50 00	(Ex)	Lifting handle	1	1
2	83 04 58		Hex.socket hd screw M16X60-A4-80	2	2
7	83 45 52		Cable tie 292X3.5 MM	1	1
7	83 45 59		Cable tie 200X2.4 PA 6/6 -55+105	1	1
8	630 68 00	(Ex)	Data plate USE 6306801 AS SPARE PART	2	2
8	630 69 00	(Ex)	Certificate plate EN	2	
8	630 70 00	(Ex)	Certificate plate FM	2	
8	630 69 01	(Ex)	Certificate plate IECEX	2	
8	801 03 02		Name plate	1	
8	630 76 00		Plate HOT WATER PRODUCT		1
9	773 29 00		Connection plate	1	1
9	83 93 50		Marking strip 5-GW (T1, T2, T15, T16)	1	1
9	832 94 00		Connection plate	1	1
9	81 65 46		Marking plate 55 GW (FUNCTIONAL GROUND)	1	1
9	681 58 00		Sticker SENSOR CONNECTED T1-T2	2	2
9	83 93 51		Marking strip W5,V5,U5,V2,W1,U2,V1,W2,U	1	1
10	82 20 88		Drive screw 4X5-A2/A4	8	8
11	82 00 11		Hex.socket hd screw M6X12-A2-70	2	
13	642 16 00	(Ex)	Earthing plate	1	
14	94 19 22		Control cable subcab 7X1,5	*	*
14	94 19 20		Control cable subcab 12X1.5 MM2 OD=18.2-21.2MM	*	*
14	94 19 30		Control cable s-flex 25X1.5 OD=19.4-21.4 MM	1	1
15	397 81 00	(Ex)	Gland screw Pr 37	1	1
23	94 20 56		Motor cable subcab 4G6+2X1.5	*	*
23	94 19 81		Motor cable subcab 4G10+S(2X0.5)	*	*
23	94 19 82		Motor cable subcab 4G16+S(2X0.5)	*	*
23	94 19 83		Motor cable subcab 4G25+S(2X0.5)	*	*
23	94 19 84		Motor cable subcab 4G35+S(2X0.5)	*	*
23	94 19 85		Motor cable subcab 3X50+2G35/2+S(2X0.5)	*	*
23	94 19 86		Motor cable subcab 3X70+2G35/2+S(2X0.5)	*	*
23	94 19 80		Motor cable subcab 7G6+S(2X0.5)	*	*
23	94 19 92		Motor cable subcab S3X10+3X10/3+S(4X0.5)	*	*
23	94 19 93		Motor cable subcab S3X16+3X16/3+S(4X0.5)	*	*

Pos. No	Part. No	Type	Denomination	Qty/Version	
				090	180
23	94 19 94		Motor cable subcab S3X25+3X16/3+S(4X0.5)	*	*
23	94 19 95		Motor cable subcab S3X35+3X16/3+S(4X0.5)	*	*
23	94 19 96		Motor cable subcab S3X50+3X25/3+S(4X0.5)	*	*
23	94 19 97		Motor cable subcab S3X70+3X35/3+2S(2X0.5)	*	*
24	605 61 01	(Ex)	Entrance flange (32)-41 MM	1	
24	605 61 01	(Ex)	Entrance flange (32)-41 MM	2	
24	605 61 21	(Ex)	Entrance flange (32)-41 MM	Cable entry for metal hose Thread : ISO G1 1/4	1
24	605 61 21	(Ex)	Entrance flange (32)-41 MM	Cable entry for metal hose Thread : ISO G1 1/4	2
24	605 61 23	(Ex)	Entrance flange (32)-41 MM	Cable entry for metal hose Thread : ISO G2	1
24	605 61 23	(Ex)	Entrance flange (32)-41 MM	Cable entry for metal hose Thread : ISO G2	2
24	605 61 25	(Ex)	Entrance flange (32)-41 MM	Cable entry for metal hose Thread : 1 1/2-11,5NPT	1
24	605 61 25	(Ex)	Entrance flange (32)-41 MM	Cable entry for metal hose Thread : 1 1/2-11,5NPT	2
24	605 61 27	(Ex)	Entrance flange (32)-41 MM	Cable entry for metal hose Thread : 2-11,5 NPT	1
24	605 61 27	(Ex)	Entrance flange (32)-41 MM	Cable entry for metal hose Thread : 2-11,5 NPT	2
24	605 61 00		Entrance flange (32)-41 MM		1
24	605 61 00		Entrance flange (32)-41 MM		2
24	605 61 20		Entrance flange (32)-41 MM	Cable entry for metal hose Thread : ISO G1 1/4	1
24	605 61 20		Entrance flange (32)-41 MM	Cable entry for metal hose Thread : ISO G1 1/4	2
24	605 61 22		Entrance flange (32)-41 MM	Cable entry for metal hose Thread : ISO G2	1
24	605 61 22		Entrance flange (32)-41 MM	Cable entry for metal hose Thread : ISO G2	2
24	605 61 24		Entrance flange (32)-41 MM	Cable entry for metal hose Thread : 1 1/2-11,5NPT	1
24	605 61 24		Entrance flange (32)-41 MM	Cable entry for metal hose Thread : 1 1/2-11,5NPT	2
24	605 61 26		Entrance flange (32)-41 MM	Cable entry for metal hose Thread : 2-11,5 NPT	1
24	605 61 26		Entrance flange (32)-41 MM	Cable entry for metal hose Thread : 2-11,5 NPT	2
25	84 41 09		Plate 35X2	1	1
26	83 04 53		Hex.socket hd screw M12X45-A4-80	2	2
26	83 04 53		Hex.socket hd screw M12X45-A4-80	4	4
31	82 74 67		O-ring 69.5X3 NBR	1	1
31	82 74 67		O-ring 69.5X3 NBR	2	2

Pos. No	Part. No	Type	Denomination	Qty/Version	
				090	180
31	82 81 75		O-ring 69.5X3 FPM	1	1
31	82 81 75		O-ring 69.5X3 FPM	2	2
32	799 32 01	(Ex)	Entrance cover For motor cable	1	
32	799 32 03	(Ex)	Entrance cover For motor cable x2	1	
32	799 32 05	(Ex)	Entrance cover For auxiliary cable For motor cable	1	
32	799 32 07	(Ex)	Entrance cover For auxiliary cable For motor cable x2	1	
32	799 32 00		Entrance cover For motor cable		1
32	799 32 02		Entrance cover For motor cable x2		1
32	799 32 04		Entrance cover For auxiliary cable For motor cable		1
32	799 32 06		Entrance cover For auxiliary cable For motor cable x2		1
33	82 78 76		O-ring 370X5.7 NBR	1	1
33	82 95 77		O-ring 370X5.7 FPM	1	1
35	83 04 58		Hex.socket hd screw M16X60-A4-80	6	6
45	82 00 11		Hex.socket hd screw M6X12-A2-70	2	2
45	83 02 79		Hex.socket hd screw M6X25-A4-70	2	2
45	82 00 17		Hex.socket hd screw M6X25-A2-70	2	2
46	82 35 73		Plain washer 6.4X12X1.6-A4-170HV	1	1
49	83 42 48		End sleeve H16/24	6	6
49	83 42 48		End sleeve H16/24	3	3
49	83 42 49		End sleeve H25/30	3	3
49	83 42 50		End sleeve H35/30D	3	3
49	83 42 51		End sleeve H50/36	3	3
49	83 42 52		End sleeve H70/40	3	3
49	83 42 49		End sleeve H25/30	6	6
49	83 42 51		End sleeve H50/36	6	6
51	83 42 62		Closed-end splice 0.33-0.82 (AWG 22-18)	2	2
53	82 00 11		Hex.socket hd screw M6X12-A2-70	2	2
53	82 00 11		Hex.socket hd screw M6X12-A2-70	4	4
54	608 62 00		Rail	1	1
54	608 62 02		Rail Prepared for: MAS 801	1	1
56	642 16 00	(Ex)	Earthing plate	1	1
56	605 73 00	(Ex)	Earthing plate	1	1
56	642 16 00	(Ex)	Earthing plate	2	2
58	82 92 77		Protective cap 100X12 MM NBR	1	1
60	82 56 26		Spring washer 119.5X100.5X1.2	1	1
61	83 30 21		Ball bearing 3311A-2Z/C3VT113	1	1
69	608 52 01	(Ex)	Stator housing	1	
69	608 52 00		Stator housing		1
72	82 75 05		O-ring 339.3X5.7 NBR	1	1
72	82 75 23		O-ring 339.3X5.7 FPM	1	1

Pos. No	Part. No	Type	Denomination	Qty/Version		
				090	180	
73	663 17 01		Shaft unit	35-25-4	1	1
73	663 17 00	(Ex)	Shaft unit	35-29-4	1	1
73	663 18 01		Shaft unit	35-25-6	1	1
73	663 18 00	(Ex)	Shaft unit	35-29-6	1	1
73	663 19 00	(Ex)	Shaft unit	35-29-8	1	1
79	642 31 01	(Ex)	Stator 35-25-4a	50 Hz 4-poles 660V-690V Y 380V-400V D P2=55kW 60 Hz 4-poles 440V-460V D P1=60KW 50 Hz 4-poles 660V-690V Y 380V-400V D P1=51KW 60 Hz 4-poles 440V-460V D P2=63kW/85hp	1	1
79	642 31 02	(Ex)	Stator 35-25-4a	50 Hz 4-poles 415V-440V D P2=55kW 50 Hz 4-poles 415V-440V D P1=51KW	1	1
79	642 31 04	(Ex)	Stator 35-25-4a	50 Hz 4-poles 500V D P2=55kW 60 Hz 4-poles 575V-600V D P1=60KW 50 Hz 4-poles 500V D P1=51KW 60 Hz 4-poles 575V-600V D P2=63kW/85hp	1	1
79	642 31 07	(Ex)	Stator 35-25-4a	60 Hz 4-poles 380V D 660V Y P1=60KW 60 Hz 4-poles 380V D 660V Y P2=63kW/85hp	1	1
79	663 80 01	(Ex)	Stator 35-29-4a	50 Hz 4-poles 690V Y 400V D P2=70kW 60 Hz 4-poles 460V D P1=72KW 50 Hz 4-poles 690V Y 400V D P1=59KW 60 Hz 4-poles 460V D P2=78kW/ 105hp	1	1
79	663 80 02	(Ex)	Stator 35-29-4a	50 Hz 4-poles 415V-440V D P2=70kW 50 Hz 4-poles 415V-440V D P1=59KW	1	1
79	663 80 04	(Ex)	Stator 35-29-4a	50 Hz 4-poles 500V D P2=70kW 60 Hz 4-poles 575V-600V D P1=73KW 50 Hz 4-poles 500V D P1=59KW 60 Hz 4-poles 575V-600V D P2=78kW/105hp	1	1
79	663 80 06	(Ex)	Stator 35-29-4a	60 Hz 4-poles 380V D P1=73KW 60 Hz 4-poles 380V D P2=78kW/ 105hp	1	1

Pos. No	Part. No	Type	Denomination	Qty/Version		
				090	180	
79	663 80 08	(Ex)	Stator 35-29-4a	50 Hz 4-poles 660V Y 380V D P2=70kW 60 Hz 4-poles 440V D P1=73KW 50 Hz 4-poles 660V Y 380V D P1=59KW 60 Hz 4-poles 440V D P2=78kW/ 105hp	1	1
79	654 81 01	(Ex)	Stator 35-25-6a	50 Hz 6-poles 660V-690V Y 380V-400V D P2=45kW 60 Hz 6-poles 440V-460V D P1=46KW 50 Hz 6-poles 660V-690V Y 380V-400V D Max P1=40KW 60 Hz 6-poles 440V-460V D P2=52kW/70hp	1	1
79	654 81 02	(Ex)	Stator 35-25-6a	50 Hz 6-poles 415V-440V D P2=45kW 50 Hz 6-poles 415V-440V D P1=40KW	1	1
79	654 81 04	(Ex)	Stator 35-25-6a	50 Hz 6-poles 500V D P2=45kW 60 Hz 6-poles 575V-600V D P1=46KW 50 Hz 6-poles 500V D P1=39KW 60 Hz 6-poles 575V-600V D P2=52kW/70hp	1	1
79	654 81 06	(Ex)	Stator 35-25-6a	60 Hz 6-poles 660V Y 380V D P1=45KW 60 Hz 6-poles 660V Y 380V D P2=52kW/70hp	1	1
79	654 82 01	(Ex)	Stator 35-29-6a	50 Hz 6-poles 690V Y 400V D P2=55kW 60 Hz 6-poles 460V D P1=55KW 50 Hz 6-poles 690V Y 400V D P1=46KW 60 Hz 6-poles 460V D P2=63kW/ 85hp	1	1
79	654 82 02	(Ex)	Stator 35-29-6a	50 Hz 6-poles 415V-440V D P2=55kW 50 Hz 6-poles 415V-440V D P1=46KW	1	1
79	654 82 04	(Ex)	Stator 35-29-6a	50 Hz 6-poles 500V D P2=55kW 60 Hz 6-poles 575V-600V D P1=55KW 50 Hz 6-poles 500V D P1=46KW 60 Hz 6-poles 575V-600V D P2=63kW/85hp	1	1
79	654 82 06	(Ex)	Stator 35-29-6a	60 Hz 6-poles 380V D P1=55KW Max ambient temp=70 DC Thermal contact 140 DC Stator leads area = 16 mm ² 60 Hz 6-poles 380V D P2=63kW/ 85hp	1	1

Pos. No	Part. No	Type	Denomination	Qty/Version		
				090	180	
79	654 82 08	(Ex)	Stator 35-29-6a	50 Hz 6-poles 660V Y 380V D P2=55kW 60 Hz 6-poles 415V-440V D Max P1=55KW 50 Hz 6-poles 660V Y 380V D P1=46KW 60 Hz 6-poles 415V-440V D P2=63kW/85hp	1	1
79	666 31 01	(Ex)	Stator 35-29-8a	50 Hz 8-poles 690V Y 400V D P2=37kW 60 Hz 8-poles 460V D P1=34KW 50 Hz 8-poles 690V Y 400V D P1=29KW 60 Hz 8-poles 460V D P2=45kW/ 60hp	1	1
79	666 31 02	(Ex)	Stator 35-29-8a	50 Hz 8-poles 415V-440V D P2=37kW 50 Hz 8-poles 415V-440V D P1=29KW	1	1
79	666 31 04	(Ex)	Stator 35-29-8a	50 Hz 8-poles 500V D P2=37kW 60 Hz 8-poles 575V-600V D P1=34KW 50 Hz 8-poles 500V D P1=29KW 60 Hz 8-poles 575V-600V D P2=45kW/60hp	1	1
79	666 31 06	(Ex)	Stator 35-29-8a	60 Hz 8-poles 380V D P1=34KW 60 Hz 8-poles 380V D P2=45kW/ 60hp	1	1
79	666 31 08	(Ex)	Stator 35-29-8a	50 Hz 8-poles 660V Y 380V D P2=37kW 60 Hz 8-poles 440V D P1=34KW 50 Hz 8-poles 660V Y 380V D P1=29KW 60 Hz 8-poles 440V D P2=45kW/ 60hp	1	1
79	679 27 02	(Ex)	Stator 35-25-4a	50 Hz 4-poles 415V-440V D P2=55kW 50 Hz 4-poles 415V-440V D P1=51KW		1
79	679 28 02	(Ex)	Stator 35-29-4a	50 Hz 4-poles 415V-440V D P2=70kW 50 Hz 4-poles 415V-440V D P1=59KW		1
79	679 29 02	(Ex)	Stator 35-25-6a	50 Hz 6-poles 415V-440V D P2=45kW 50 Hz 6-poles 415V-440V D P1=40KW		1
79	679 30 02	(Ex)	Stator 35-29-6a	50 Hz 6-poles 415V-440V D P2=55kW 50 Hz 6-poles 415V-440V D P1=46KW		1

Pos. No	Part. No	Type	Denomination	Qty/Version	
				090	180
79	679 31 02	(Ex)	Stator 35-29-8a 50 Hz 8-poles 415V-440V D P2=37kW 50 Hz 8-poles 415V-440V D P1=29KW		1
82	608 59 00		Cooling jacket STEEL Material:Steel	1	1
82	608 59 01		Cooling jacket STAINLESS STEEL Material:stainless steel (ASTM 316L)	1	1
83	82 75 02		O-ring 289.3X5.7 NBR	1	1
83	82 81 51		O-ring 289.3X5.7 FPM	1	1
84	82 75 12		O-ring 479.3X5.7 NBR	1	1
84	82 81 52		O-ring 479.3X5.7 FPM	1	1
88	655 80 00		Cable entry unit (23)-26 MM	1	1
88	655 80 01		Cable entry unit (26)-29 MM	1	1
88	655 80 03		Cable entry unit (32)-35 MM	1	1
88	655 80 04		Cable entry unit (35)-38 MM	1	1
88	655 80 05		Cable entry unit (38)-41 MM	1	1
88	655 80 00		Cable entry unit (23)-26 MM	2	2
88	655 80 01		Cable entry unit (26)-29 MM	2	2
88	655 80 03		Cable entry unit (32)-35 MM	2	2
88	655 80 04		Cable entry unit (35)-38 MM	2	2
88	655 80 02		Cable entry unit (29)-32 MM	1	1
88	655 80 06		Cable entry unit (41)-44 MM	1	1
88	655 80 07		Cable entry unit (44)-47 MM	1	1
88	655 80 02		Cable entry unit (29)-32 MM	2	2
88	655 80 05		Cable entry unit (38)-41 MM	2	2
88	655 80 06		Cable entry unit (41)-44 MM	2	2
88	655 80 07		Cable entry unit (44)-47 MM	2	2
101	650 51 00		Cable unit FLS10	1	1
103	663 04 00	(Ex)	Level sensor FLS10	1	
103	791 99 00		Level sensor		1
105	608 53 01	(Ex)	Bearing holder	1	
105	608 53 00		Bearing holder		1
107	82 59 29		Retaining ring SGA 95	1	1
108	82 44 28		Supporting washer 95X115X3.5	2	2
109	83 30 28		Ball bearing 3319A-2Z/C3VT113	1	1
110	83 07 64		Retaining ring 7 3/4"	1	1
120	642 13 00		Plug	1	1
122	82 76 85		O-ring 17X3 NBR	1	1
122	82 79 15		O-ring 17X3 FPM	1	1
129	608 56 00		Seal housing cover	1	1
130	82 78 84		O-ring 405.26X3.53 NBR	1	1
131	82 75 12		O-ring 479.3X5.7 NBR	1	1
131	82 81 52		O-ring 479.3X5.7 FPM	1	1
133	83 04 58		Hex.socket hd screw M16X60-A4-80	6	6

Pos. No	Part. No	Type	Denomination	Qty/Version		
				090	180	
141	800 93 30		Mechanical seal WCCR/WCCR, WCCR/WCCR FPM	Material inner : Cemented carbide (WCCR) - Cemented carbide (WCCR) Material outer : Cemented carbide (WCCR) - Cemented carbide (WCCR) Seal O-ring Mtrl : FPM	1	1
141	800 93 31		Mechanical seal WCCR/WCCR, RSIC/ RSIC FPM	Material inner : Cemented carbide (WCCR) - Cemented carbide (WCCR) Material outer : Silicone carbide (RSiC) - Silicone carbide (RSiC) Seal O-ring Mtrl : FPM	1	1
158	669 73 12		Impeller	LT 50Hz Curve code: 810	1	1
158	669 73 23		Impeller	LT 50Hz Curve code: 812	1	1
158	669 73 36		Impeller	LT 50Hz Curve code: 814	1	1
158	669 73 45		Impeller	LT 50Hz Curve code: 816	1	1
158	669 73 57		Impeller	LT 50Hz Curve code: 818	1	1
158	669 72 09		Impeller	LT 50Hz Curve code: 620	1	1
158	669 72 20		Impeller	LT 50Hz Curve code: 622	1	1
158	669 72 32		Impeller	LT 50Hz Curve code: 624	1	1
158	669 72 42		Impeller	LT 50Hz Curve code: 626	1	1
158	669 72 50		Impeller	LT 60Hz Curve code: 628	1	1
158	608 69 20		Impeller	MT 50Hz Curve code: 630	1	1
158	608 69 30		Impeller	MT 50Hz Curve code: 632	1	1
158	608 69 40		Impeller	MT 50Hz Curve code: 634	1	1
158	608 69 50		Impeller	MT 50Hz Curve code: 636	1	1
158	608 69 60		Impeller	MT 60Hz Curve code: 638	1	1
158	608 69 70		Impeller	MT 60Hz Curve code: 639	1	1
158	608 63 00		Impeller	HT 50Hz Curve code: 450	1	1
158	608 63 10		Impeller	HT 50Hz Curve code: 452	1	1
158	608 63 20		Impeller	HT 50Hz Curve code: 454	1	1
158	608 63 30		Impeller	HT 50Hz Curve code: 456	1	1
158	608 63 40		Impeller	HT 50Hz Curve code: 458	1	1
158	605 96 00		Impeller	HT 60Hz Curve code: 460	1	1
158	605 96 10		Impeller	HT 60Hz Curve code: 462	1	1
158	605 96 20		Impeller	HT 60Hz Curve code: 464	1	1
158	605 96 30		Impeller	HT 60Hz Curve code: 466	1	1
158	605 96 40		Impeller	HT 60Hz Curve code: 468	1	1
162	82 38 01		Plain washer 17X30X6-A4-170HV		1	1
163	82 69 41		Protective plug		4	4
169	83 04 60		Hex.socket hd screw M16X120-A4 80		1	1
193	83 04 53		Hex.socket hd screw M12X45-A4-80		4	4
200	704 77 00		Pump housing	LT DN 350 Drilled inlet Prepared for zinc anodes (only for P and S installation)	1	1
200	704 77 01		Pump housing	LT DN 350 Drilled acc. to: EN 1092-2 tab. 8	1	1
200	704 77 05		Pump housing	LT DN 350 Drilled acc. to: ANSI B16.1-89; tab.5	1	1

Pos. No	Part. No	Type	Denomination	Qty/Version		
				090	180	
200	704 77 07		Pump housing	LT DN 350 Drilled acc. to: EN 1092-2 tab. 9	1	1
200	704 77 31		Pump housing	LT DN 350 Drilled acc. to: EN 1092-2 tab. 8 Installation: Z Drainage plug	1	1
200	704 77 35		Pump housing	LT DN 350 Drilled acc. to: ANSI B16.1-89; tab.5 Installation: Z Drainage plug	1	1
200	704 77 37		Pump housing	LT DN 350 Drilled acc. to: EN 1092-2 tab. 9 Installation: Z Drainage plug	1	1
200	704 74 00		Pump housing	LT DN 300 Drilled inlet Prepared for zinc anodes (only for P and S installation)	1	1
200	704 74 01		Pump housing	LT DN 300 Drilled acc. to: EN 1092-2 tab. 8	1	1
200	704 74 05		Pump housing	LT DN 300 Drilled acc. to: ANSI B16.1-89; tab.5	1	1
200	704 74 07		Pump housing	LT DN 300 Drilled acc. to: EN 1092-2 tab. 9	1	1
200	704 74 31		Pump housing	LT DN 300 Drilled acc. to: EN 1092-2 tab. 8 Installation: Z Drainage plug	1	1
200	704 74 35		Pump housing	LT DN 300 Drilled acc. to: ANSI B16.1-89; tab.5 Installation: Z Drainage plug	1	1
200	704 74 37		Pump housing	LT DN 300 Drilled acc. to: EN 1092-2 tab. 9 Installation: Z Drainage plug	1	1
200	704 55 00		Pump housing	MT DN 250 Drilled inlet Prepared for zinc anodes (only for P and S installation)	1	1
200	704 55 01		Pump housing	MT DN 250 Drilled acc. to: EN 1092-2 tab. 8	1	1
200	704 55 05		Pump housing	MT DN 250 Drilled acc. to: ANSI B16.1-89; tab.5	1	1
200	704 55 07		Pump housing	MT DN 250 Drilled acc. to: EN 1092-2 tab. 9	1	1
200	704 55 31		Pump housing	MT DN 250 Drilled acc. to: EN 1092-2 tab. 8 Installation: Z Drainage plug	1	1
200	704 55 35		Pump housing	MT DN 250 Drilled acc. to: ANSI B16.1-89; tab.5 Installation: Z Drainage plug	1	1
200	704 55 37		Pump housing	MT DN 250 Drilled acc. to: EN 1092-2 tab. 9 Installation: Z Drainage plug	1	1
200	704 58 00		Pump housing	HT DN 150 Drilled inlet Prepared for zinc anodes (only for P and S installation)	1	1
200	704 58 06		Pump housing	HT DN 150 Drilled acc. to: EN 1092-2 tab. 9 ANSI B16.1-89; tab.5	1	1
200	704 58 36		Pump housing	HT DN 150 Drilled acc. to: ANSI B16.1-89; tab.5 EN 1092-2 tab. 9 Installation: Z Drainage plug	1	1
209	796 74 00		Sliding bracket	Guide bar dimension : 80mm	1	1

Pos. No	Part. No	Type	Denomination	Qty/Version		
				090	180	
209	607 38 00		Sliding bracket	Guide bar dimension : 80mm	1	1
209	669 84 00		Sliding bracket	Optional	1	1
210	83 04 58		Hex.socket hd screw M16X60-A4-80		4	4
211	457 68 00		Discharge connection DN300	LT DN 250	1	1
211	479 26 00		Discharge connection DN300	MT DN 250	1	1
211	379 32 00		Discharge connection 8"	MT DN 200	1	1
211	295 57 00		Discharge connection DN150	HT DN 150	1	1
211	309 31 00		Discharge connection DN150	HT Thread: 6-8 NPSM Outer Outlet DN 150	1	1
211	309 31 01		Discharge connection DN150	HT Thread: ISO G6 Outer Quick coupling: Storz diam=160 mm Outlet DN 150	1	1
212	84 34 35		Hexagon head screw M20X90-A2-70	LT MT	4	4
212	84 34 35		Hexagon head screw M20X90-A2-70	LT MT	12	12
212	84 34 34		Hexagon head screw M20X80-A2-70	HT	8	8
213	82 35 26		Plain washer 21X37X3-A2-170HV		8	8
213	82 35 26		Plain washer 21X37X3-A2-170HV		24	24
213	82 35 26		Plain washer 21X37X3-A2-170HV		16	16
214	80 95 96		Stud 24X100-A2-70	LT	2	2
214	80 96 04		Stud 24X120-A2-70	LT	2	2
215	82 23 62		Hexagon nut M20-A2-70	LT MT HT	4	4
215	82 23 62		Hexagon nut M20-A2-70	LT MT HT	12	12
215	82 23 62		Hexagon nut M20-A2-70	LT MT HT	8	8
216	380 25 01		Gasket 370 MM	LT	1	1
216	384 45 00		Gasket 8"	MT	1	1
216	295 64 00		Gasket 6"	HT	1	1
217	437 88 01		Stand compl. S/T INSTALLATION		1	1
218	84 34 05		Hexagon head screw M16X50-A2-70		4	4
219	82 35 23		Plain washer 17X30X3-A2-170HV		4	4
227	83 19 36		Coupling part		1	1
229	667 40 01		Sticker		2	2
231	93 00 77		Shrink hose ID=6.4 MM		*	*
231	93 00 78		Shrink hose ID=9.5 MM		*	*
231	93 00 81		Shrink hose ID=19.1 MM		*	*
232	83 53 58		Terminal clamp WDU6/10		3	3
232	83 53 58		Terminal clamp WDU6/10			4
233	83 53 61		Terminal clamp WDU16.1000V		6	6
233	83 53 61		Terminal clamp WDU16.1000V		8	8
233	83 53 17		Terminal clamp WDU35/IK/ZA		6	6
233	83 53 17		Terminal clamp WDU35/IK/ZA		8	8
233	83 53 62		Terminal clamp WEIDMÜLLER WDU 70N		8	8
234	83 53 67		Cross connection WQV 16N/2		3	3
234	650 20 02		Cross connection WQV 16N/10		1	1
234	83 53 67		Cross connection WQV 16N/2		4	4

Pos. No	Part. No	Type	Denomination	Qty/Version	
				090	180
234	83 53 49		Cross connection WQV 35N /2	3	3
234	650 20 03		Cross connection WQV 35N/10	1	1
234	83 53 49		Cross connection WQV 35N /2	4	4
234	83 53 63		Cross connection WQV 70N/2	4	4
235	83 53 54		End support WEW 35/2	2	2
236	83 53 50		Partition	1	1
239	800 45 00		El.lead through unit 9X + 8X	1	1
239	800 45 03		El.lead through unit 9X + 8X	1	1
240	607 48 05	(Ex)	Spring	1	1
241	82 75 04		O-ring 319.3X5.7 NBR	1	1
241	82 81 64		O-ring 319.3X5.7 FPM	1	1
242	608 54 01	(Ex)	Adapter	1	
242	608 55 11	(Ex)	Adapter Cooling jacket	1	
242	608 54 00		Adapter		1
242	608 55 10		Adapter Cooling jacket		1
243	83 04 61		Hex.socket hd screw M12X25-A4-80	2	2
245	82 75 12		O-ring 479.3X5.7 NBR	1	1
245	82 81 52		O-ring 479.3X5.7 FPM	1	1
246	82 78 84		O-ring 405.26X3.53 NBR	1	1
247	82 81 73		O-ring 149.3X5.7 FPM	1	1
251	642 13 00		Plug	2	2
252	82 76 85		O-ring 17X3 NBR	2	2
252	82 79 15		O-ring 17X3 FPM	2	2
253	608 58 02		Cooling jacket	1	1
254	608 57 02		Flow diffuser	1	1
256	608 44 00		Wire bow	3	3
257	82 44 38		Supporting washer 170X200X3.5	1	1
258	720 17 00		Sleeve unit	1	1
267	725 07 00		Plug	4	4
269	518 89 04	(Ex)	Leakage detect.unit	1	1
270	608 31 00	(Ex)	Lock washer	1	
278	669 88 01		Vibration sensor	1	1
279	82 23 32		Hexagon nut M8-A4-70	2	2
302	691 83 00		Connector unit INTENDED FOR "MAS"	1	1
313	82 81 59		O-ring 119.5X3 FPM	1	1
327	83 97 97		Temperature sensor	1	1
328	665 86 00		Temperature sensor PT100, 2-LEADS 1500MM	1	1
329	718 81 00		Special washer	1	1
331	94 05 81		Insulating hose D=5 MM	*	*
332	665 86 00		Temperature sensor PT100, 2-LEADS 1500MM	1	1
335	83 53 77		Terminal clamp WPE 2.5 WS	1	1
336	83 42 36		End sleeve 0.75 MM2; L=6 MM	2	2

Pos. No	Part. No	Type	Denomination	Qty/Version	
				090	180
338	82 40 61		Plain washer 24.5X35X2-A2-70	1	1
339	84 17 90		Seal sleeve (10)-12 MM FPM	1	1
339	84 17 92		Seal sleeve (14)-16 MM NBR	1	1
339	84 17 94		Seal sleeve (18)-20 MM NBR	1	1
339	84 17 95		Seal sleeve (20)-22 MM NBR	1	1
340	678 58 12	(Ex)	Cable clip 10-(12) MM	1	1
340	678 58 16	(Ex)	Cable clip 14-(16) MM	1	1
340	678 58 20	(Ex)	Cable clip 18-(20) MM	1	1
340	678 58 22	(Ex)	Cable clip 20-(22) MM	1	1
341	633 11 01		Gland screw ISO G1 1/4"	1	1
341	633 11 01		Gland screw ISO G1 1/4"	2	2
341	633 11 05		Gland screw ISO G2"	1	1
341	633 11 05		Gland screw ISO G2"	2	2
341	633 11 04		Gland screw 1 1/2" NPT	1	1
341	633 11 04		Gland screw 1 1/2" NPT	2	2
341	633 11 06		Gland screw 2" NPT	1	1
341	633 11 06		Gland screw 2" NPT	2	2
342	82 23 63		Hexagon nut M24-A2-70	4	4
343	82 35 28		Plain washer 25X44X4-A2-170HV	4	4
350	823 05 00		Pump monitoring	1	1
351	82 62 75		Transformer	1	1
352	83 45 59		Cable tie 200X2.4 PA 6/6 -55+105	1	1
353	83 45 59		Cable tie 200X2.4 PA 6/6 -55+105	1	1
354	83 43 60		Cable lug UL/CSA 0.50-1.65 MM2 M4	1	1
355	718 81 00		Special washer	1	1
800	82 97 00		O-ring kit	1	1
800	82 97 01		O-ring kit	1	1
808	769 32 00		N-pump kit CURVE: 810 "N-LT"	1	1
808	769 32 01		N-pump kit CURVE: 812	1	1
808	769 32 02		N-pump kit CURVE: 814 "N-LT"	1	1
808	769 32 03		N-pump kit CURVE: 816	1	1
808	769 32 04		N-pump kit CURVE: 818	1	1
808	769 32 05		N-pump kit CURVE: 620 "N-LT"	1	1
808	769 32 06		N-pump kit CURVE: 622	1	1
808	769 32 07		N-pump kit CURVE: 624 "N-LT"	1	1
808	769 32 08		N-pump kit CURVE: 626	1	1
808	769 32 09		N-pump kit CURVE: 628	1	1
808	769 32 10		N-pump kit CURVE: 630 "N-MT"	1	1
808	769 32 11		N-pump kit CURVE: 632	1	1
808	769 32 12		N-pump kit CURVE: 634 "N-MT"	1	1
808	769 32 13		N-pump kit CURVE: 636	1	1
808	769 32 14		N-pump kit CURVE: 638 "N-MT"	1	1
808	769 32 15		N-pump kit CURVE: 639	1	1

Pos. No	Part. No	Type	Denomination	Qty/Version	
				090	180
808	769 32 17		N-pump kit CURVE: 452 "N-HT"	1	1
808	769 32 18		N-pump kit CURVE: 454 "N-HT"	1	1
808	769 32 19		N-pump kit CURVE: 456 "N-HT"	1	1
808	769 32 20		N-pump kit CURVE: 458	1	1
808	769 32 22		N-pump kit CURVE: 460	1	1
808	769 32 23		N-pump kit CURVE: 462 "N-HT"	1	1
808	769 32 24		N-pump kit CURVE: 464	1	1
808	769 32 25		N-pump kit CURVE: 466 "N-HT"	1	1
808	769 32 26		N-pump kit CURVE: 468	1	1
900	657 17 05		Basic repair kit	1	1
900	657 17 06		Basic repair kit	1	1
901	90 20 76		Monopropylene glycol	*	*
912	82 76 85		O-ring 17X3 NBR	3	3
912	82 79 15		O-ring 17X3 FPM	3	3



ООО «Бауманс Груп» - официальный партнер фирмы Flygt в России.

Тел: +7 495 121 49 50

Эл. почта: info@baumgroup.ru

Сайт: www.baumgroup.ru